

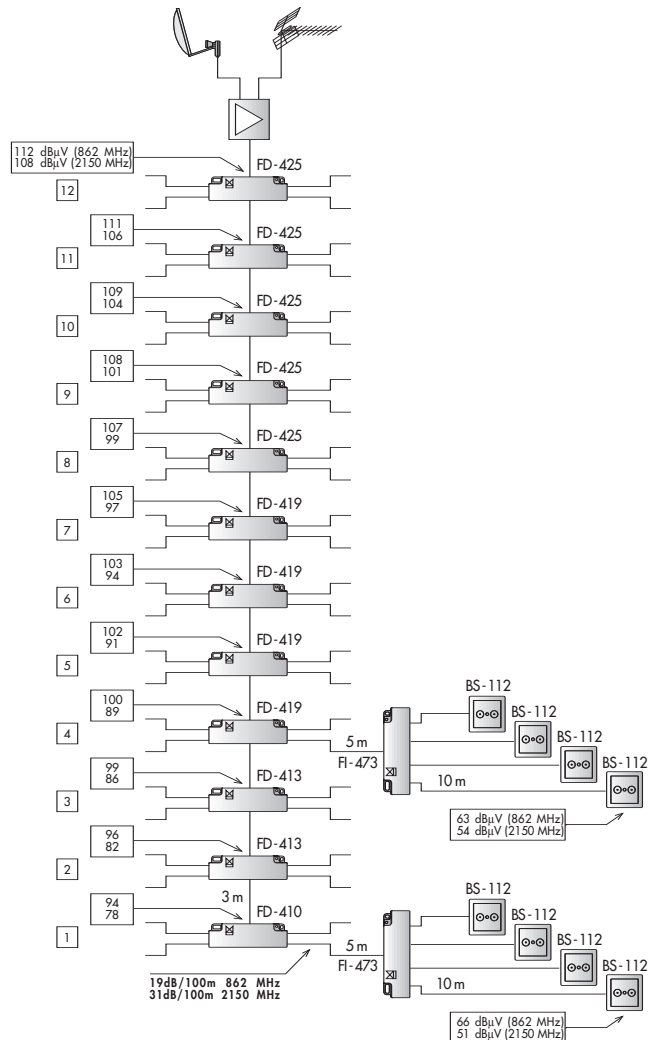

INSTALLATION EXAMPLES 906

SMATV installation with equalised IF tap-offs

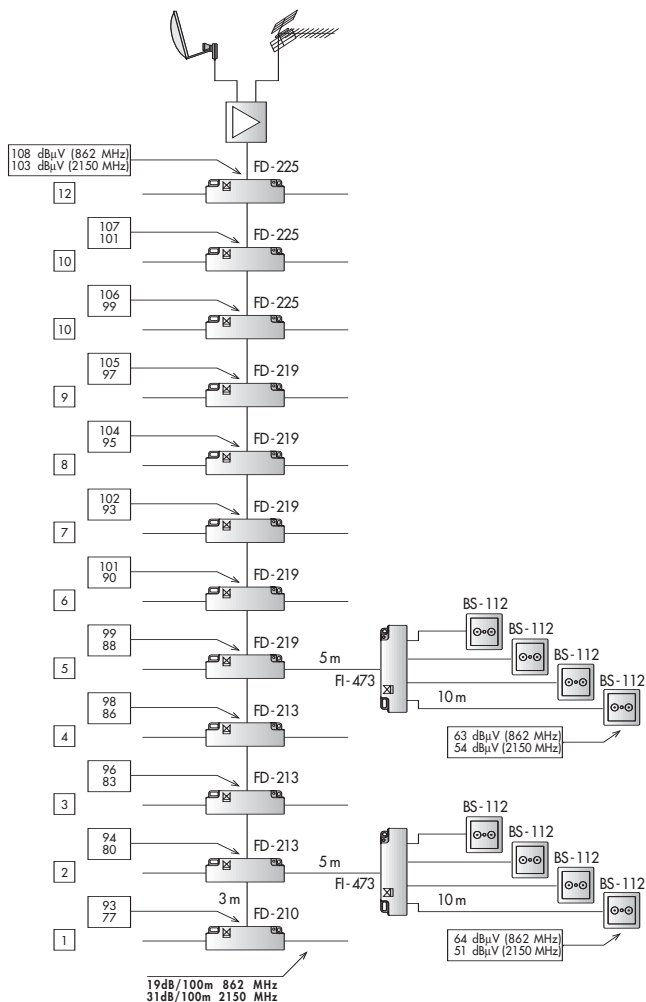

Tap-offs with different attenuations are used to compensate the levels at the different outlets. In buildings with fewer floors, the indicated tap-offs are used on the lower floors, and the necessary head-end level will be that which is indicated on the input of the tap-off. The levels are indicated on the weakest outlets.